

# COMPARISON BETWEEN AKIMA AND BETA-SPLINE INTERPOLATORS FOR DIGITAL ELEVATION MODELS

by

**Luiz Alberto Vieira Dias**

Chairman, Center for Associated Technologies, CTE  
National Institute for Space Research - INPE  
12201 São José dos Campos, SP, BRAZIL  
ISPRS Commission IV - WG 7

and

**Carlos Eduardo Nery**

Assistant Professor  
Paraíba Valley University - UNIVAP  
12201 São José dos Campos, SP, BRAZIL  
ISPRS Commission IV - WG 7

## ABSTRACT

When interpolators are used in Digital Elevation Models, it is known that certain geographic features are not well represented. This work compares the performances of two interpolators for different geographic features: the Akima and the Beta-spline. The Akima interpolator is widely used in DEM's, while the Beta-Splines have user defined parameters that can control the shape of the surface without changing the control points. The results are presented in graphical form.

**KEY WORDS:** Digital Elevation Models, DEM, DTM, Numerical Interpolation, Akima, Beta-Splines.

## 1. INTRODUCTION

A problem that frequently arises when it is necessary to select an interpolator for use in Digital Elevation Models, DEM, is the choice of the best, or at least good, interpolator for a given condition.

This work compares the widely used Akima interpolator with the Beta-Spline interpolator. Their characteristics are very different, thus it is expected that they complement each other, according to the situation.

A characteristic they share is the computer run time, that is fast for both. The environment used in this work was: the files were prepared on IBM PC-like computers, the visualization was done on workstations, and the graphs made in laser jet printers.

Session 2 presents a brief description of both interpolators, in Session 3 the results obtained are shown, and the conclusions are discussed in Session 4.

## 2. AKIMA AND BETA-SPLINE INTERPOLATORS

### 2.1 - Akima Interpolator

The Akima surface interpolator (Akima, 1978) is a very interesting method, for it runs very fast on computers, passes for all vertices of the control polyhedron, has continuity of zeroth (passes by points) and first order (tangent continuity), at the patches borders. It has not second order continuity, thus the curvature is not

equal at the border of patches. However, for terrain description, this property is not essential, since the terrains vary in an abrupt way in certain cases.

Mathematically it is represented as a cubic polynomial in two variables (Akima, 1978):

$$z(x,y) = S (A_{ij} * x^i * y^j) \quad (2)$$

$$i=0,3$$

$$j=0,3$$

The determination of the coefficients  $A_{ij}$  is made by means of a method devised by Akima (1978). The method uses the Hermite interpolator, but instead of using the, generally unknown, derivatives at the control vertices, Akima devised a method to determine the derivatives based on the values of the neighbouring vertices. It uses, for each patch, with 4 points, the 32 surrounding points (Akima, 1978). For each patch, there is a different cubic polynomial in two variables, to represent the interpolated surface.

### 2.2 - Beta-Spline Interpolator

The Beta-Spline Interpolator has the very interesting property of permitting the user to modify the shape of the interpolated surface without changing the vertices of the control polyhedron. This enables one to shape the surface in order to comply with some features already known (Barsky, 1987).

Mathematically it is represented as a series, like a Bézier surface (Foley and VanDam 1984). The Beta-spline parametric formulation is as below:

$$q(u,v) = \sum_i \sum_j (V_{ij} * B_{ij}(u,v, \beta_1, \beta_2)) \quad (1)$$

$$i=0, n-1$$

$$j=0, m-1$$

where  $\sum$  stands for summation,  $u$  and  $v$  are the parametric variables,  $m$  and  $n$  the line and column numbers,  $V_{ij}$  the polyhedron control vertices, and  $B_{ij}()$  the base function. The base function is dependent on the parameters  $\beta_1$  and  $\beta_2$ , that control, respectively, the bias (toward the control vertices with smaller or larger values of  $u$  and  $v$ ) and the tension ("force" that pulls the surface toward the control vertices and stretches it like a tension in a rubber membrane). The bases are not dependent on the position of the control vertices. The interpolated surface lies inside the convex hull formed by the control polyhedron. The surface has zeroth, first and second order geometric continuity, but this can be relaxed by means of double or triple point superimposed to each other.

### 3. RESULTS

It was selected a terrain with a variety of features. Figure 1 presents a restitution from aerial photography, a courtesy from AERODATA S/A. It was considered as the original data. Figure 2 shows an undersampled part of Figure 1, that was used as control polyhedron.

A patch was chosen for the comparisons. In this patch five tests were performed:

A) An Akima interpolation.

B) Beta-spline interpolation with no tension and no bias ( $\beta_1=1$ ,  $\beta_2=0$ ). In this case the Beta-spline is reduced to a B-spline (Barsky, 1978).

C) Beta-spline interpolation with moderate bias and no tension,  $\beta_1=+8$ ,  $\beta_2=0$ .

D) Beta-spline interpolation with moderate bias to the other side, no tension,  $\beta_1=1/8$ ,  $\beta_2=0$ .

E) Beta-spline interpolation with no bias, high tension  $\beta_1=1$  and  $\beta_2=90$ . This case approaches a linear interpolation.

Figures 3 to 7 present these cases.

### 4. CONCLUSIONS

It is seen visually that the Beta-splines are a better fit in certain features, like valleys, rivers and ridges than the Akima, while the Akima is a better interpolator on the average.

The Beta-splines can model the shape of certain features, but since the surface does not pass by the control vertices, the model is positioned "under" the convex hull. This can be compensated, but it is an added complication. There is no automatic way to choose the proper betas, its choice has been dictated by experience. These drawbacks can be overcome with the populatization of the use of Beta-splines, when new procedures may be determined.

There is much more work to be done, including a careful quantitative evaluation. The authors are still working in this subject, and it is hoped that soon further results could be presented.

### 5. ACKNOWLEDGEMENTS

The authors would like to thanks INPE, IBM Brasil, UNIVAP, and AERODATA for valuable support during the duration of this research.

### 6. BIBLIOGRAPHY

AKIMA, H., 1978. A Method of Bivariate Interpolation and Smooth Surface Fitting for Irregularly Distributed Data Points. ACM Transactions on Mathematical Software, volume 4, pgs 148-159.

BARSKY, B.A., 1987. Computer Graphics and Geometric Modelling Using Beta-splines. Springer-Verlag, New York, NY, USA.

FOLEY, J.D., and VanDam, A., 1984. Fundamentals of Interactive Computer Graphics. Addison-Wesley, Reading, MA, USA.

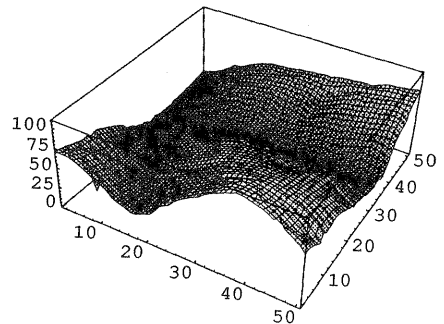

Fig. 1 - Original Data Set.

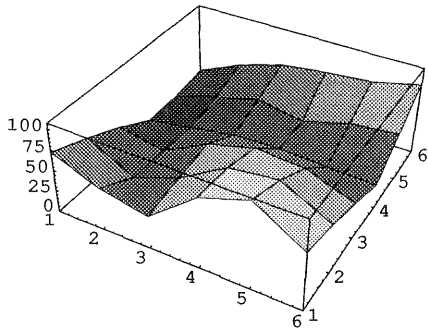

Fig. 2- Original Undersample.

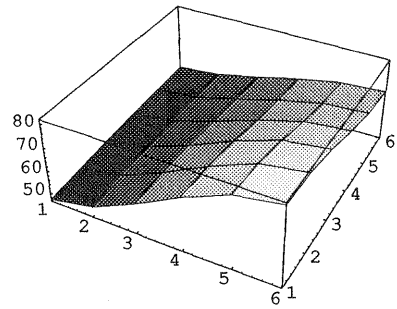

Fig. 3 - Akima Interpolation.

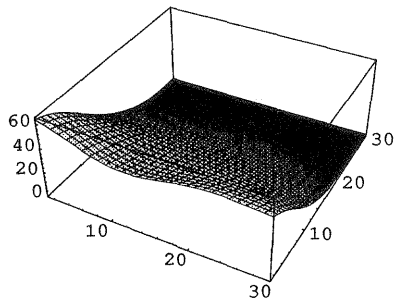

Fig. 4 - Beta1=1, Beta2=0.

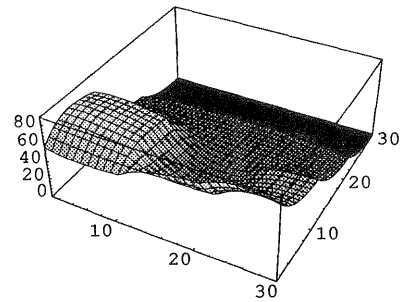

Fig. 5 - Beta1=8, Beta2=0

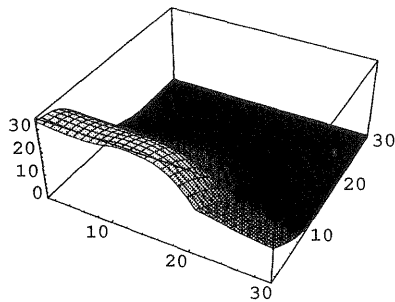

Fig. 6 - Beta1=1/8, Beta2=0.

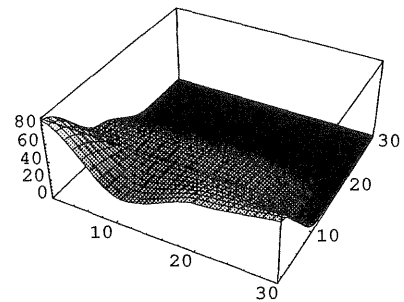

Fig. 7 - Beta1=1, Beta2=90.